



 **LIBERVIT**  
*maritime tactical*

tactical equipment to operate on land  
& underwater





Yvan CARDONA's word,

Since 1993, the LIBERVIT company researches, develops and manufactures tools to facilitate the missions from various police's group, gendarmerie and armed forces.

Throughout these years, we have never ceased to create and bring new and effective solutions to the many problems brought to us. Over time, we've built ourselves a reputation for seriousness, quality and efficiency, enabling us today to be active over 5 continents.

With LIBERVIT maritime tactical, we are becoming, once again, the pioneers and the leaders in a field as complex and specialized as the one embracing watery and underwater operations.

After 3 years of research, developments, tests and filing several international patents, we are proud to present through this book our new and high-quality equipment. This is the beginning of a wider range to which we will be adding to within the next few years.

The LIBERVIT team is joining me in wishing you a pleasant read.

CEO  
Yvan CARDONA





# Contents' table

Quality & Safety	5
M38 hydraulic power unit & accessories in transport case	8 - 9
M63 hydraulic cutters, buoy & accessories in transport case	10 - 11
M64 hydraulic spreader, buoy & accessories in transport case	12 - 13
M65 hydraulic telescopic jack & extension, buoy & accessories in transport case	14 - 15
Mpower - hydraulic power unit	16 - 17
Mflex2 & Mflex4 - hydraulic hoses	18 - 19
Mconnect2 & Mconnect4 - service handles	20 - 21
Mseries & MU400 - hydraulic cutters	22 - 25
ME4 - hydraulic spreader	26 - 27
MVT5 - hydraulic jack & RMVT5 - extension	28 - 29
Mstab, Mrope & Srope - buoy and its length adjustable sling & security	30 - 31
LOAD250 - weight bags	32 - 33
VDT - Transport cases	34 - 39
M3863 land, watery and underwater extrication cutting unit	42 - 47
M3864 land, watery and underwater spreading and lifting unit	48 - 53
M3865 land, watery and underwater sabotage & heavy-duty work unit	54 - 59
M3863/64/65 land, watery and underwater extrication heavy-duty work unit	60 - 65
OXsea land, watery and underwater thermic cutting unit	66 - 73
Tcage - training cage	74 - 77
Dry diving suit & thermal undersuit	80 - 83
Maintenance - maintenance equipment	84 - 93
DS80 - depth simulator / test stand	94 - 97
LIBERVIT training courses	98 - 99

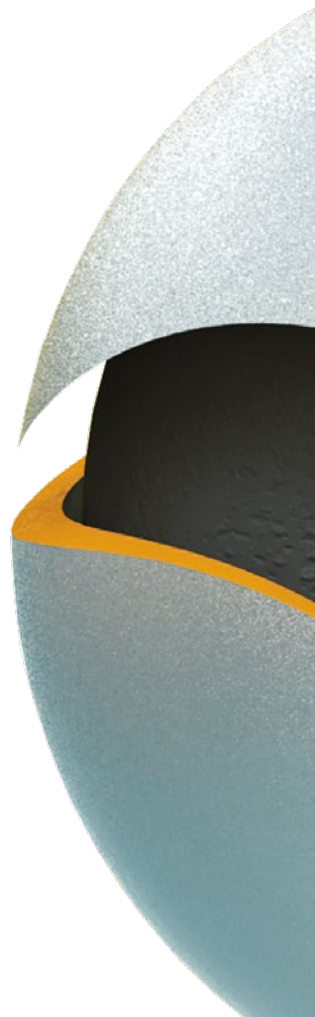

# Quality & Safety

Our organization, from engineering to customers' service is ISO 9001 certified. It guarantees a high quality, life-long performance and complete reliability of our tools and equipment. All our tools undergo rigorous tests and control before shipment.



ISO 9001 certified



CE certified



360° technology to work in any position



up to 80 m depth (262 ft) certified (any water)



neutral buoyancy certified

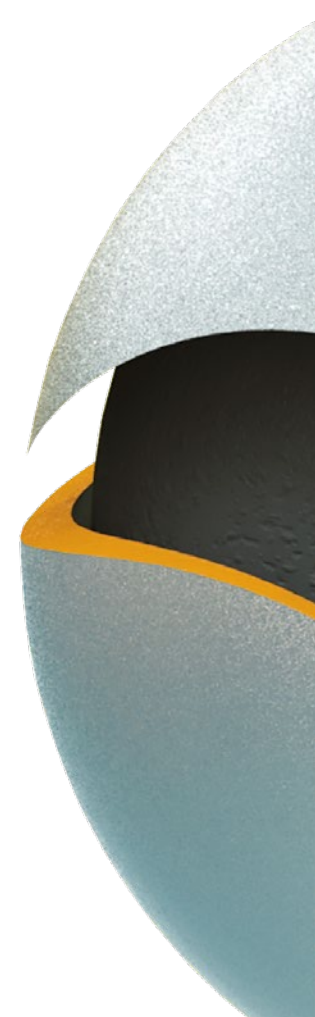



# Technical specifications





# M38

power unit & accessories in transport case

The M38 case includes :

hydraulic power unit	ref. Mpower
hydraulic hose	ref. Mflex2
service handle	ref. Mconnect2
weight bags for buoyancy settings	qty 6, ref. LOAD250
safety sling	ref. Srope
Mpower maintenance bag with tools	ref. MP/MB1
PELICASE transport case	ref. VDT/M38
dimensions	781 x 520 x 295 mm - 31 x 20 x 11 inch
weight empty	16.5 kg - 2.5 st
weight packed	47 kg - 7 st









# M63

hydraulic cutters, buoy & accessories in transport case

The M63 case includes :

short curved blades hydraulic cutter	ref. MBP40 or
long curved blades hydraulic cutter	ref. MBPL40 or
short straight blades hydraulic cutter	ref. MLD40 or
long straight blades hydraulic cutter	ref. MLDL40 or
U shape blades hydraulic cutter	ref. MU400
buoy	ref. Mstab-63
weight bags for buoyancy settings	qty 6, ref. LOAD250
length adjustable sling	ref. Mrope
safety sling	ref. Srope
PELICASE transport case	ref. VDT/M63
case dimensions	781 x 520 x 295 mm - 31 x 20 x 11 inch
empty case weight	21.5 kg - 3 st
Mseries cutter, buoy & accessories' case weight	40 kg - 6 st
MU400 cutter, buoy & accessories' case weight	40.3 kg - 6.5 st



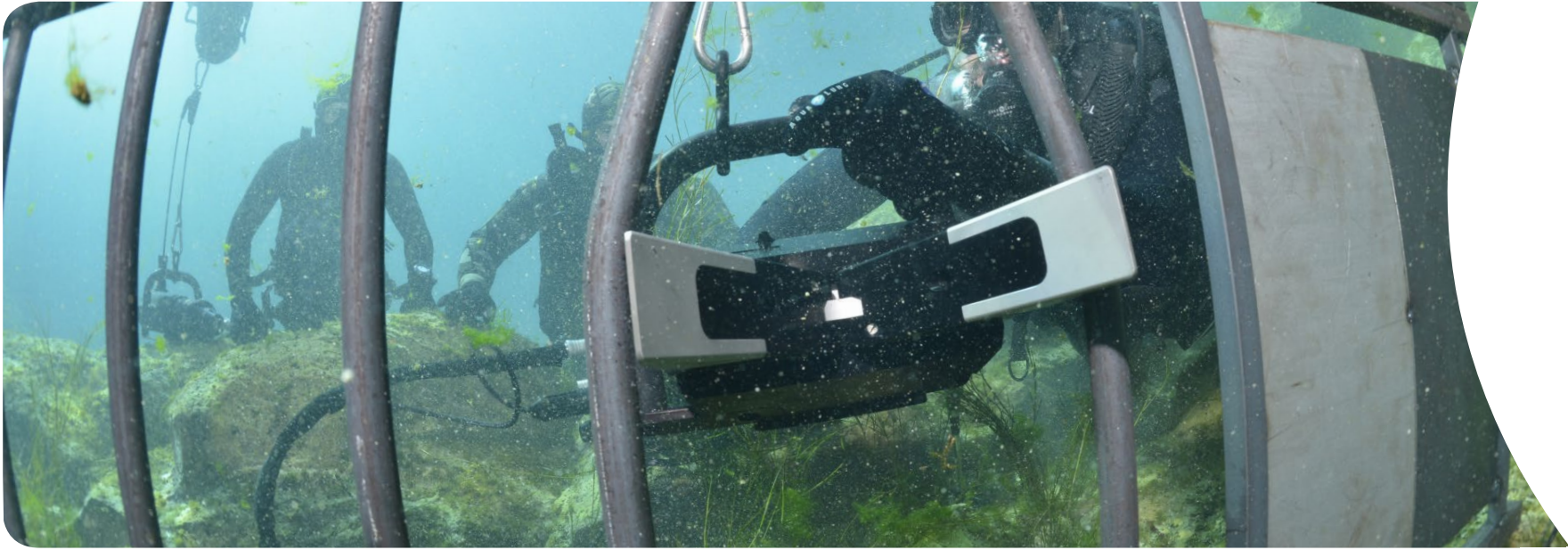

# M64

hydraulic spreader, buoy & accessories in transport case



The M64 case includes :

hydraulic spreader	ref. ME4
buoy	ref. Mstab-64
weight bags for buoyancy settings	qty 6, ref. LOAD250
length adjustable sling	ref. Mrope
safety sling	ref. Srope
PELICASE transport case	ref. VDT/M64
dimensions	781 x 520 x 295 mm - 31 x 20 x 11 inch
empty case weight	21.5 kg - 3 st
case weight with ME4 spreader, buoy and accessories	36 kg - 5.5 st





# M65

hydraulic jack & extension, buoy & accessories in transport case



The M65 case includes :

telescopic hydraulic jack	ref. MVT5
jack extension	ref. RMVT5
delivered with own buoy	ref. Mstab-65
weight bags for buoyancy settings	qty 6, ref. LOAD250
length adjustable sling	ref. Mrope
safety sling	ref. Srope
PELICASE transport case	ref. VDT/M65
dimensions	781 x 520 x 295 mm- 31 x 20 x 11 inch
empty case weight	21.5 kg - 3 st
case weight with MVT5 jack & RMVT5 extension, buoy & accessories	33.1 kg - 5 st

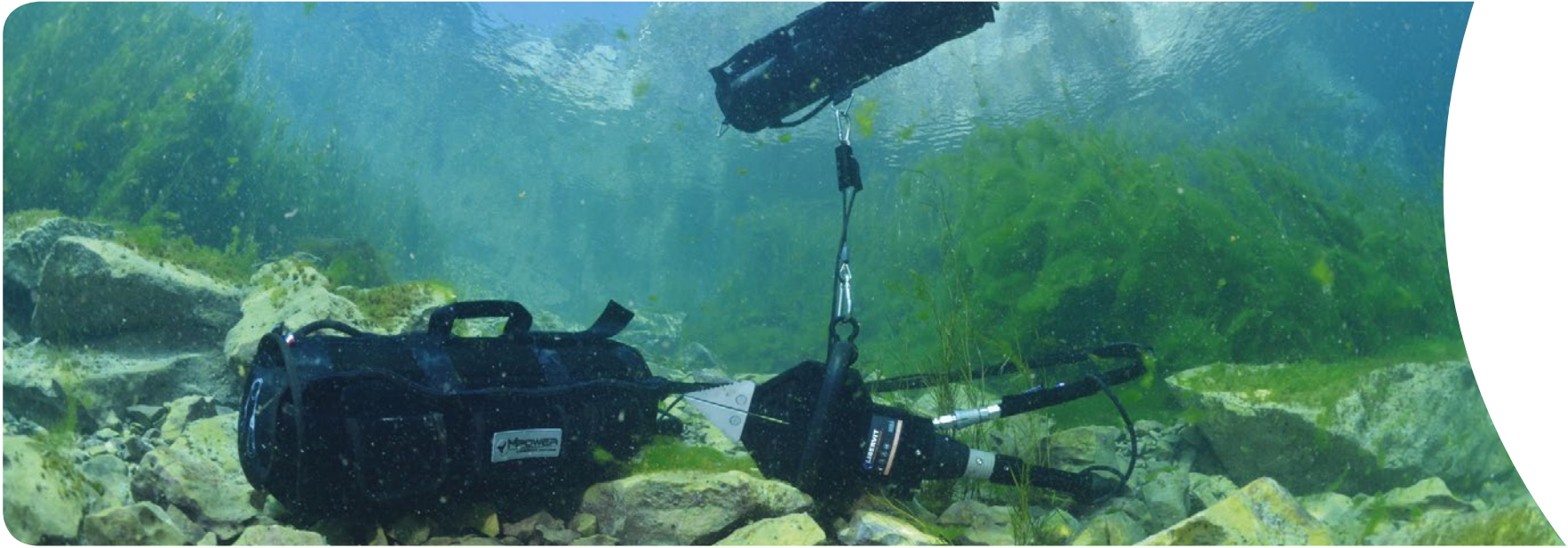

# Mpower

hydraulic power unit



hydraulic power unit	ref. Mpower
service pressure	300 bar
supply	12 V lithium battery
average working time	45 min
battery's charge indicator	ref. MCI, qty 1
Lithium battery charger	ref. MCB/L, qty 1
battery maximum charge time	90 min
maximum depth use	80 m / 262 ft
dessicant dehumidifier cartridge	qty 1, ref. HYSB
protection sleeve	qty 1, ref. MP/H
protection sleeve colours	dark grey/black nylon (option olive green)
transport handle	qty 1
outhaul attachments	qty 2
weight bags for buoyancy settings	qty 6
underwater connection/disconnection	yes
pressurized tool connection/disconnection	yes
single-handed connection/disconnection	yes
anti-pollution hydraulic coupling	yes
T360 technology (any position use)	yes
land & underwater use	yes
neutral buoyancy	yes
underwater air bubbles production	no
dimensions	670 x Ø210 mm - 26 x Ø8 inch
weight	22 kg - 48.5 lbs
weight bags for buoyancy settings	qty 6, ref. LOAD250
weight bag weight	250 gr - 9 oz
safety sling	qty 1, ref. Slope
Slope & snap-hook tested on drive-bench	yes
sling length	700 mm - 2 ft
sling weight	300 gr - 10.5 oz
Mpower's maintenance bag	qty 1, ref. MP/MB1

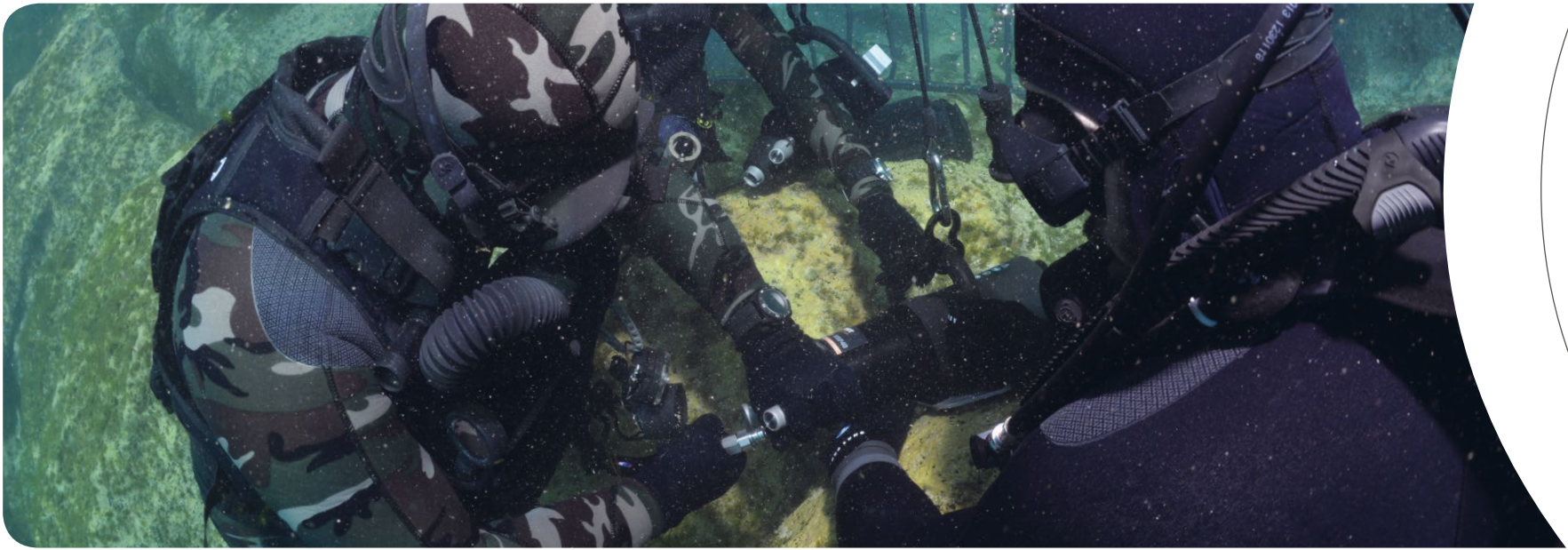



# Mflex2 & Mflex4

hydraulic hoses



hydraulic hose

Mflex2 length

Mflex2 weight

Mflex4 length

Mflex4 weight

protection sleeve colours

maximum depth use

underwater connection/disconnection

pressurized tool connection/disconnection

single-handed connection/disconnection

anti-pollution hydraulic coupling

underwater air bubbles production

land & underwater use

neutral buoyancy

ref. Mflex2 - ref. Mflex4

2 m - 6.5 ft

1.1 kg - 2.5 lbs

4 m - 13 ft

1.9 kg - 4 lbs

dark grey/black nylon (option olive green)

80 m / 262 ft

yes

yes

yes

yes

no

yes

no

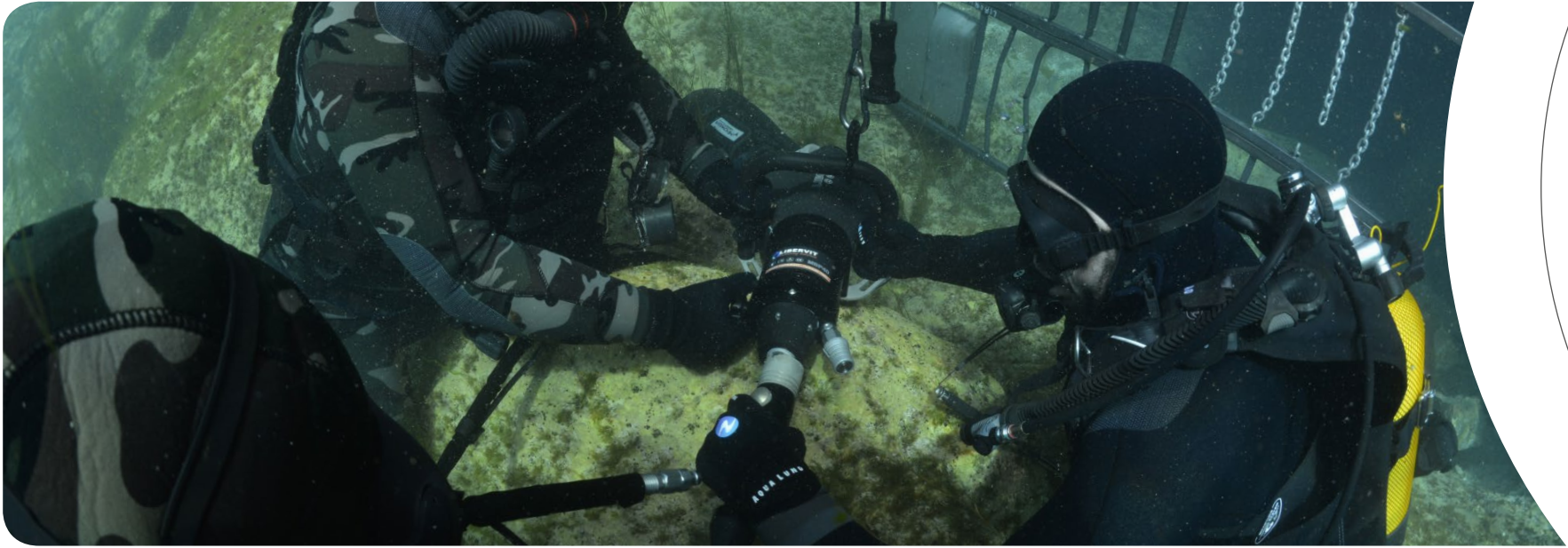



# Mconnect2 & Mconnect4

service handles



service handle	ref. Mconnect 2 - ref. Mconnect 4
Mconnect 2 length	2 m - 6 ft
Mconnect 2 weight	1.3 kg - 3 lbs
Mconnect 4 length	4 m - 13 ft
Mconnect 4 weight	1.6 kg - 3.5 lbs
maximum depth use	80 m / 262 ft
underwater connection/disconnection	yes
pressurized tool connection/disconnection	yes
single-handed connection/disconnection	yes
underwater air bubbles production	no
land & underwater use	yes
neutral buoyancy	no



# Mseries

hydraulic cutters



Mseries cutters maximum cutting force	400 kN
maximum cutting capacity on round bar*	Ø 22 mm - 0.8 inch
transport handle	qty 1
Mrope attachment ring	yes
safety check valve	yes
colours	dark grey/black (option olive green)
short curved blades hydraulic cutter	ref. MBP40
blades maximum opening	75 mm - 3 inch
dimensions	510 x 242 x 197 mm - 20 x 9.5 x 7.5 inch
weight	13.24 kg - 29.1 lbs
long curved blades hydraulic cutter	ref. MBPL40
blades maximum opening	105 mm - 4 inch
dimensions	551 x 242 x 197 mm - 21.5 x 9.5 x 7.5 inch
weight	13.8 kg - 30.4 lbs
short straight blades hydraulic cutter	ref. MLD40
blades maximum opening	143 mm - 5.5 inch
dimensions	560 x 250 x 247 mm - 22 x 10 x 10 inch
weight	13 kg - 28.6 lbs
long straight blades hydraulic cutter	ref. MLDL40
blades maximum opening	203 mm - 9 inch
dimensions	590 x 242 x 197 mm - 23.2 x 9.5 x 7.5 inch
weight	13.74 kg - 30.2 lbs
maximum depth use	80 m / 262 ft
underwater connection/disconnection	yes
pressurized tool connection/disconnection	yes
single-handed connection/disconnection	yes
anti-pollution hydraulic coupling	yes
buoyancy controled with a buoy	yes
neutral buoyancy when used with its Mstab-63 buoy	yes
underwater air bubbles production	no
land & underwater use	yes

\* steel used during cutting trials of Ø 22 mm (1 inch) bars, NF S235/EN10027

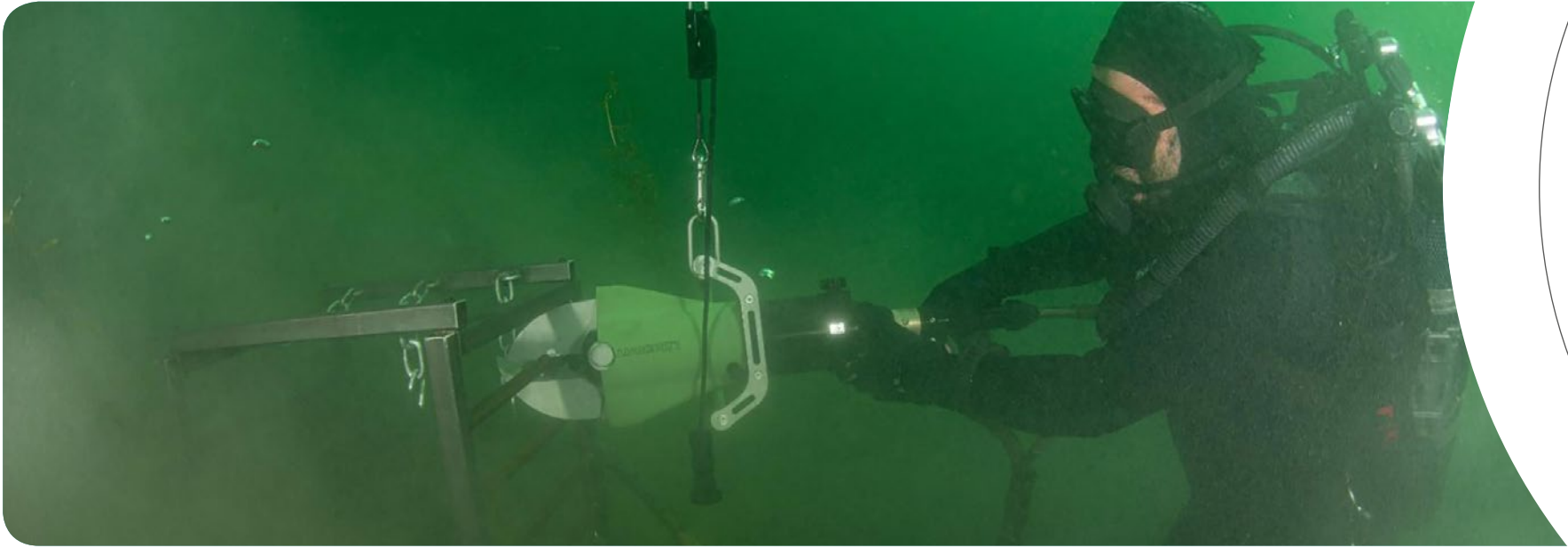

# MU400

hydraulic cutter



U shape blades hydraulic cutter	ref. MU400
maximum cutting force	400 kN
maximum cutting capacity on round bar*	Ø 22 mm - 0.8 inch
transport handle	qty 1
M rope attachment ring	yes
safety check valve	yes
colours	dark grey/black (option olive green)
blades maximum opening	160 mm - 6.3 inch
dimensions	600 x 242 x 197 mm - 24 x 9.5 x 8.5 inch
weight	14.7 kg - 32.4 lbs
maximum depth use	80 m / 262 ft
underwater connection/disconnection	yes
pressurized tool connection/disconnection	yes
single-handed connection/disconnection	yes
anti-pollution hydraulic coupling	yes
buoyancy controlled with a buoy	yes
neutral buoyancy when used with its Mstab-63 buoy	yes
underwater air bubbles production	no
land & underwater use	yes

\* steel used during cutting trials of Ø 22 mm (1 inch) bars, NF S235/EN10027



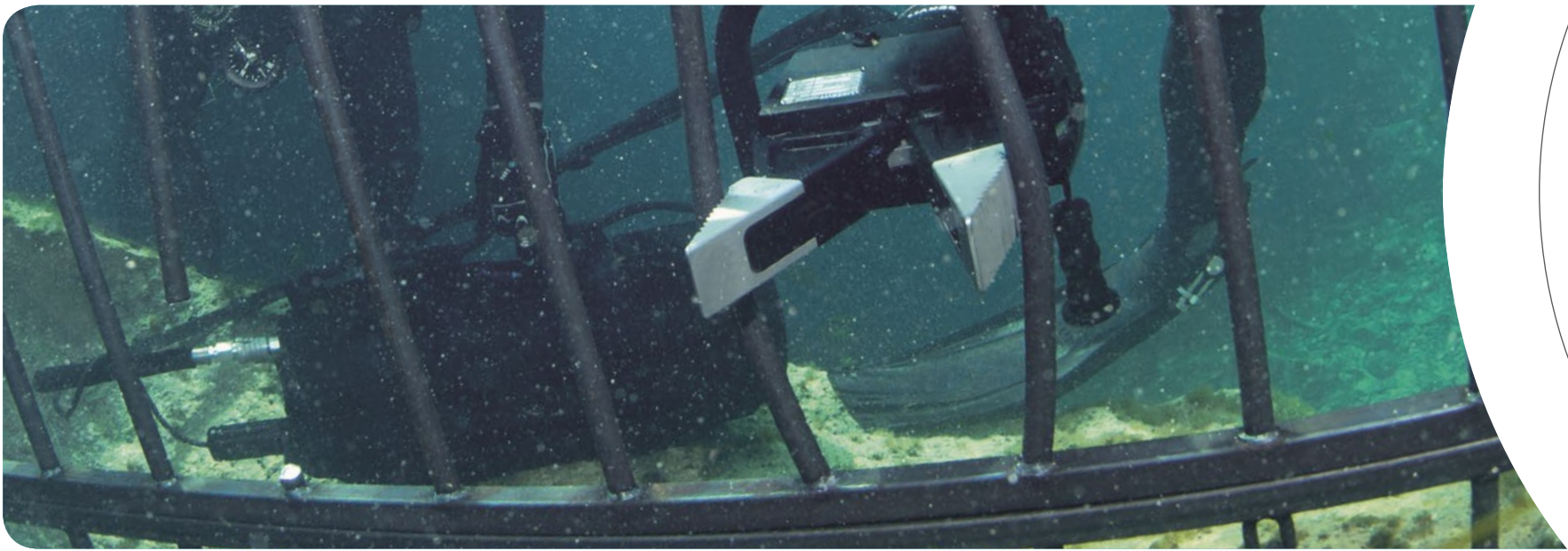

# ME4

hydraulic spreader



hydraulic spreader	ref. ME4
arms maximum opening	330 mm - 13 inch
maximum spreading force	84 kN
transport handle	qty 1
Mrope fixation ring	yes
hydraulic check-valve	yes
colours	dark grey/black (option olive green)
dimensions	469 x 266 x 228 mm - 18.5 x 10 x 9 inch
weight	14.5 kg - 28 lbs
maximum depth use	80 m / 262 ft
underwater connection/disconnection	yes
pressurized tool connection/disconnection	yes
single-handed connection/disconnection	yes
anti-pollution hydraulic coupling	yes
buoyancy controled with a buoy	yes
neutral buoyancy when used with its Mstab-64 buoy	yes
gunderwater air bubbles production	no
land & underwater use	yes



# MVT5 & RMVT5

telescopic hydraulic jack & extension



telescopic hydraulic jack	ref. MVT5
first stage push force	100 kN
second stage push force	45 kN
length retracted	540 mm - 1.7 ft
jack's stroke	385 mm - 1.2 ft
total length deployed	925 mm - 2.8 ft
transport handle	qty 1
Mrope attachment ring	yes
safety check valve	yes
colour	dark grey/black (option olive green)
dimensions	535 x 250 x 170 mm - 21 x 9.5 x 6.5 inch
weight	11 kg - 24 lbs

telescopic jack extension	ref. RMVT5
dimensions	205 x 65 mm - 8 x 2.5 inch
weight	680 gr - 1.5 lbs

maximum depth use	80 m / 262 ft
underwater connection/disconnection	yes
pressurized tool connection/disconnection	yes
single-handed connection/disconnection	yes
anti-pollution hydraulic coupling	yes
buoyancy controled with a buoy	yes
neutral buoyancy when used with its Mstab-65 buoy	yes
underwater air bubbles production	no
land & underwater use	yes





1.



2.



# Mstab - Mrope - Srope

buoys, weight bags & slings



1. Mseries & MU400*cutters' buoy	ref. Mstab-63
ME4* spreader's buoy	ref. Mstab-64
MVT5* hydraulic jack & RMVT5*extension's buoy	ref. Mstab-65
maximum depth use	80 m- 262 feet
horizontal & vertical use	yes
Mstab-63 & Mstab-64 dimensions	Ø 180 mm x 660 mm- Ø 7 inch x 26 inch
Mstab-65 dimensions	Ø 180 mm x 600 mm - Ø 7 inch x 23.5 inch
Mstab-65 pocket for RMVT5 extension	qty 2
weight bags pocket	yes
Srope pocket	yes
Mstab-63 & Mstab-64 weight	5 kg- 11 lbs
Mstab-65 buoy weight	5 kg- 11 lbs
colours	dark grey/black (option olive green)
underwater air bubbles production	no
2. weight bags for buoyancy settings	qty 6, ref. LOAD250
weight bag weight	250 gr / 9 oz
3. length adjustable sling	ref. Mrope
horizontal or vertical use	yes
tool-buoy shortest distance	350 mm- 14 inch
tool-buoy longest distance	1 m- 3.2 ft
weight	600 gr-1.3 lbs
Mrope and fasteners tested on a test bench	yes
4. safety sling	ref. Srope
safety sling length	700 mm - 2 ft
weight	300 gr - 10.5 oz
Srope and fasteners tested on a test bench	yes

\*cutter, spreader or telescopic jack delivered with its own buoy, weight bags, length adjustable and safety sling.



**LIBERVIT**  
mariti

rincer et sécher  
rinse and dry after use  
riadacar y secar despues  
sciacquare e asciugare  
nach geprauch,  
skölj och torka  
afspoelen en afdo  
بعد الاستخدام  
使用後はすすぎ  
冲洗和使用后的干

www.libervit.com



**LIBERVIT**  
mariti

rincer et sécher  
rinse and dry aft  
riadacar y secar d  
sciacquare e asc  
nach geprauch,  
skölj och torka e  
afspoelen en af  
بعد الاستخدام  
使用後はすすぎ  
冲洗和使用后的干

www.libervit.com

# LOAD250

weight bag

weight bag  
fabric  
colour  
small handle  
dimensions  
weight

ref. LOAD250  
CORDURA® soft apparel  
dark grey / black  
qty 2  
100 x 100 mm - 4 x 4 inch  
250 gr / 9 oz







The M3863 - M3864 - M3865 - M3863/64 - M3863/65 - M3864/65 et M3863/64/65 units are packed and delivered in PELICASE, these cases are the strongest and most reliable found on the market which is the reason why we choose them.

All our cases meet military standards and are air transport safe.

Each case is fitted with a black powder coated stainless steel frame to hold the tool and its accessories in place.

The case can be rinsed inside out with fresh water without any risks.

Once closed, the VDT cases are the perfect protection either for transport or for storage.

Within the following pages you will discover the cases we use and their main technical specifications.







# VDT

## M38 unit's transport case



PELICASE transport case for hydraulic unit :

reference	VDT/M38
dimensions	781 x 520 x 295 mm - 31 x 20 x 11 inch
empty case weight	21.5 kg - 3 st
fully equipped case weight	47 kg - 7 st
delivered with M38 (page 9)	yes
transport / telescopic handles - wheels	yes
colour	black
IP rated (case closed)	IP67
fresh water washable	yes



# VDT

## M63 - M64 - M65 units' transport cases



cutters transport case*	ref. VDT/M63
dimensions	781 x 520 x 295 mm- 31 x 20 x 11 inch
empty case weight	21.5 kg - 3 st
case weight with Mseries cutters, buoy and accessories	40 kg - 6 st
case weight with MU400 cutters, buoy and accessories delivered with M63 (page 11)	40.3 kg - 6.5 st yes
spreader transport case*	ref. VDT/M64
dimensions	781 x 520 x 295 mm- 31 x 20 x 11 inch
empty case weight	21.5 kg - 3 st
case weight with ME4 spreader, buoy and accessories delivered with M64 (page 13)	36 kg - 5.5 st yes
telescopic jack transport case*	ref. VDT/M65
dimensions	781 x 520 x 295 mm- 31 x 20 x 11 inch
empty case weight	21.5 kg - 3 st
case weight with telescopic jack & extension, buoy and accessories delivered with M65 (page 15)	33.1 kg - 5 st yes
*All cases :	
transport / telescopic handles - wheels	yes
colour	black
IP rated (case closed)	IP67
fresh water washable	yes











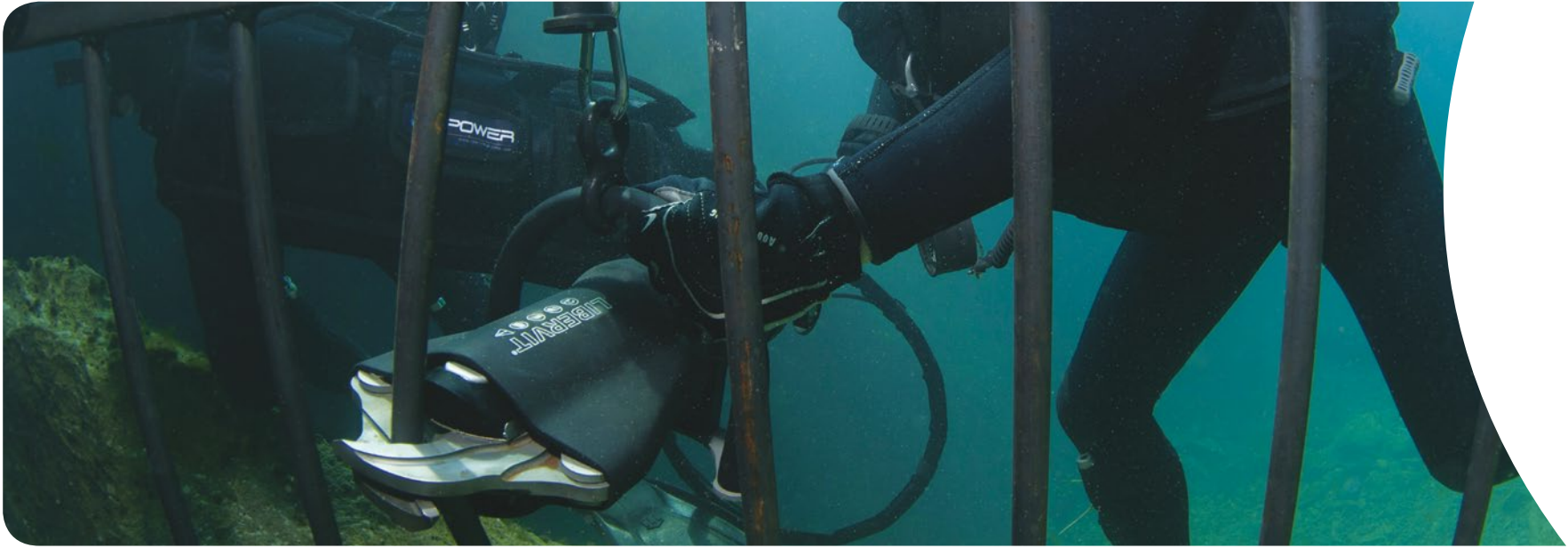

# M3863

land, watery & underwater cutting unit

The M3863 unit was developed for atypical breaching situations faced by the operations' teams of the Police and Army.

Through many technical meetings with concerned parties, we defined their needs exact specifications. It seemed that during specific missions, either on land or underwater, they lacked the proper tools to cut, prise open, raise or push; tools that could be silent and self-sufficient, and that would not produce any air bubbles when in use.

**Designed to cut through all kind of material the M3863 comes with a cutter, its own buoyancy float, a hydraulic hose combined with an electric service handle and a hydraulic power unit.**

Different models are available from the Mseries cutters : short curved blades MBP40 & long curved blades MBPL40, short straight blades MLD40 & long straight blades MLDL40 and the U shape blades MU400.\*

On motor vehicles, ships, aircrafts, etc. these cutters will help you through any land, watery and underwater breaching operations.

Each cutter has its own Mstab float, keeping its own mobility and neutral buoyancy and leaving the diver free of any weight. When used from a distance, the cutter maintains its neutral buoyancy even after cutting, giving the operator and the equipment full safety. The Mpower hydraulic power unit with the T360 technology feeds all of the Mseries cutters, works in any positions and has neutral buoyancy. The integrated and re-loadable battery provides 45 minutes of working autonomy.

The combined 2 m- 6 ft hydraulic hose and electric service handle connects the hydraulic power unit to the cutter and is used to power the Mpower from the tool. For safety reasons, it might be necessary, to loosen the service handle from the tool and use it as a cabled remote to cut from a distance.

The standard distance between the operator and the cutter is 4 m- 13 ft. If a longer distance is required, we can provide an additional 4 m- 13 ft dual hydraulic hose/ electric service handle, providing an 8 m- 26 ft safe cutting distance from the working tool.

Note that if you own, as well as the Mseries cutters, the MU400 cutter or the ME4 spreader, you can use either tool with the Mpower and use them one after the other. To do so, disconnect the service handle from the tool you are using and connect it to the required tool, you can proceed both on land and underwater.



\* All cutting test were done using standard steel, Ø 22 mm- 0,8 inch bar, NF S235/EN10027



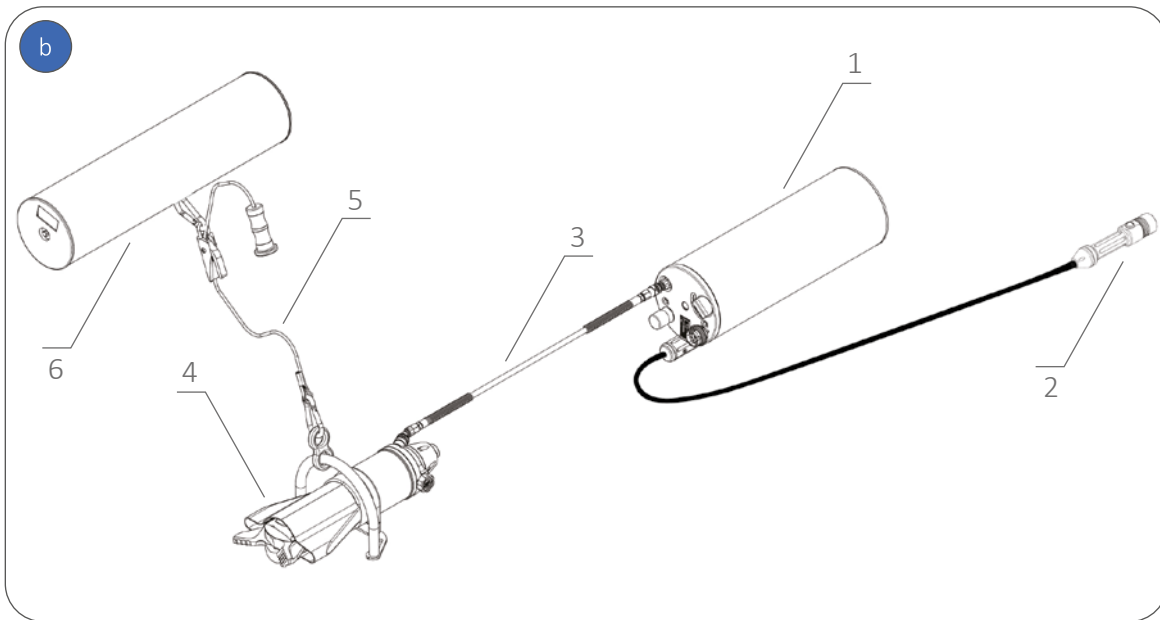
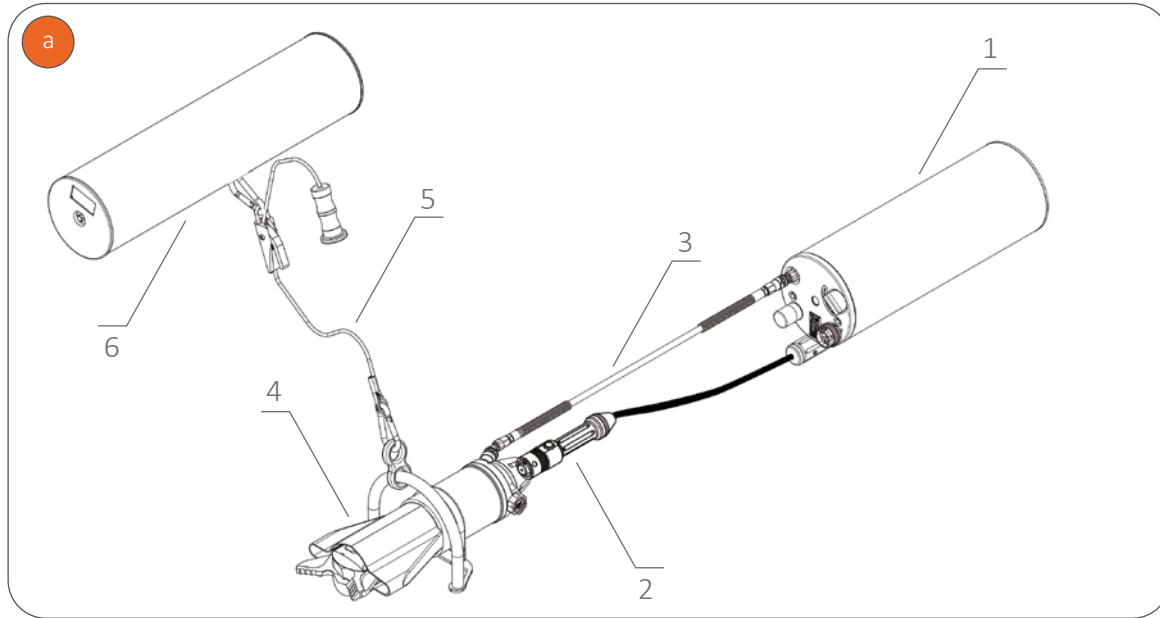

# M3863

land, watery & underwater cutting unit

- |     |   |   |  |
|-----|---|---|--|
| M38 | [ | 1 | Mpower - hydraulic power unit                              |
|     |   | 2 | Mconnect2 or Mconnect4 - service handles / cabled remote   |
|     |   | 3 | Mflex2 or Mflex4 - hydraulic hoses                         |
| M63 | [ | 4 | Mseries or MU400 - cutters                                 |
|     |   | 5 | Mrope - length adjustable sling for cutter and buoy        |
|     |   | 6 | Mstab-63 - cutter's neutral buoyancy buoy and safety sling |

Hydraulic couplings and electrical connectors can be connected and disconnected underwater.

The Mstab can float at the horizontal or at the vertical position.

The Mrope is a length adjustable sling placed between the cutter and the Mstab.

The Mstab and the weight bags work together to give the cutter its neutral buoyancy.

The Mpower is used with weight bags too to get neutral buoyancy.

The usual way to use the Mconnect2 & Mconnect4 is attached to the cutter. If, for safety reasons, it is preferable to operate from a distance, you can release the remote control from the tool.

The cutter can be used either way :

- a** When cutting, the operator, holding the handle, will start the cutter by pushing on the button on the service handle(2).
- b** For safety reasons, the operator can remotely control the cutting process by pushing on the button on the release service handle(2).



# M3863

land, watery & underwater cutting unit





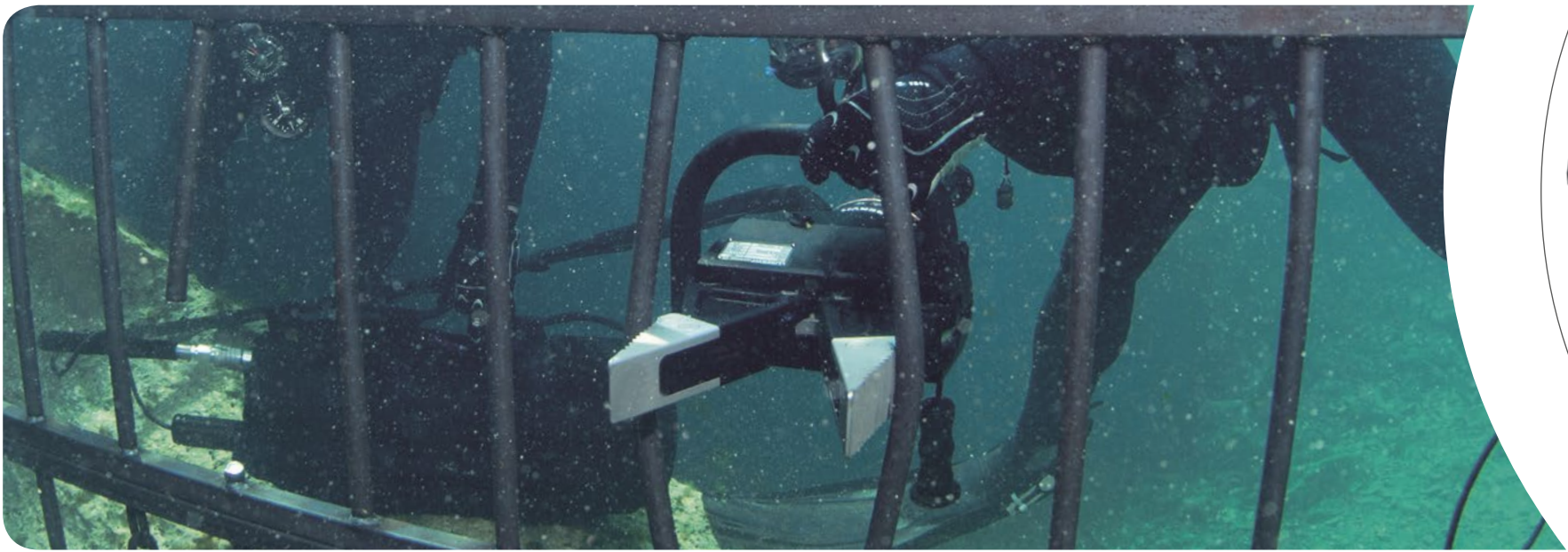

# M3864

land, watery & underwater spreading unit

The M3864 units was developed for atypical breaching situations faced by the operations' teams of the Police and Army.

Through many technical meetings with concerned parties, we defined their needs exact specifications. It seemed that during specific missions, either on land or underwater, they lacked the proper tools to cut, prise open, raise or push; tools that could be silent and self-sufficient, and that would not produce any air bubbles when in use.

**Designed to spread and lift, the M3864 comes with a spreader, its own buoyancy float, a hydraulic hose combined with an electric service handle and a hydraulic power unit.**

On motor vehicles, ships, aircrafts, etc. this spreader will help you through any land, watery and underwater extrication operations.

The ME4 spreader has its own Mstab float, keeping its own mobility and neutral buoyancy and leaving the diver free of any weight. When used from a distance, the spreader maintains its neutral buoyancy even after spreading or lifting, giving the operator and the equipment full safety. The Mpower hydraulic power unit with the T360 technology feeds the ME4 spreader, works in any positions and has neutral buoyancy. The integrated and re-loadable battery provides 45 minutes of working autonomy.

The combined 2 m- 6 ft hydraulic hose and electric service handle connects the hydraulic power unit to the spreader and is used to power the Mpower from the tool. For safety reasons, it might be necessary, to loosen the service handle from the tool and use it as a cabled remote to spread or lift from a distance.

The standard distance between the operator and the spreader is 4 m - 13 ft. If a longer distance is required, we can provide an additional 4 m - 13 ft dual hydraulic hose/ electric service handle, providing an 8 m - 26 ft safe spreading distance from the working tool.

Note that if you own, as well as the ME4 spreader, the Mseries cutters and MU400 cutter, you can use either tool with the Mpower and use them one after the other.

To do so, disconnect the service handle from the tool you are using and connect it to the required tool, you can proceed both on land and underwater.



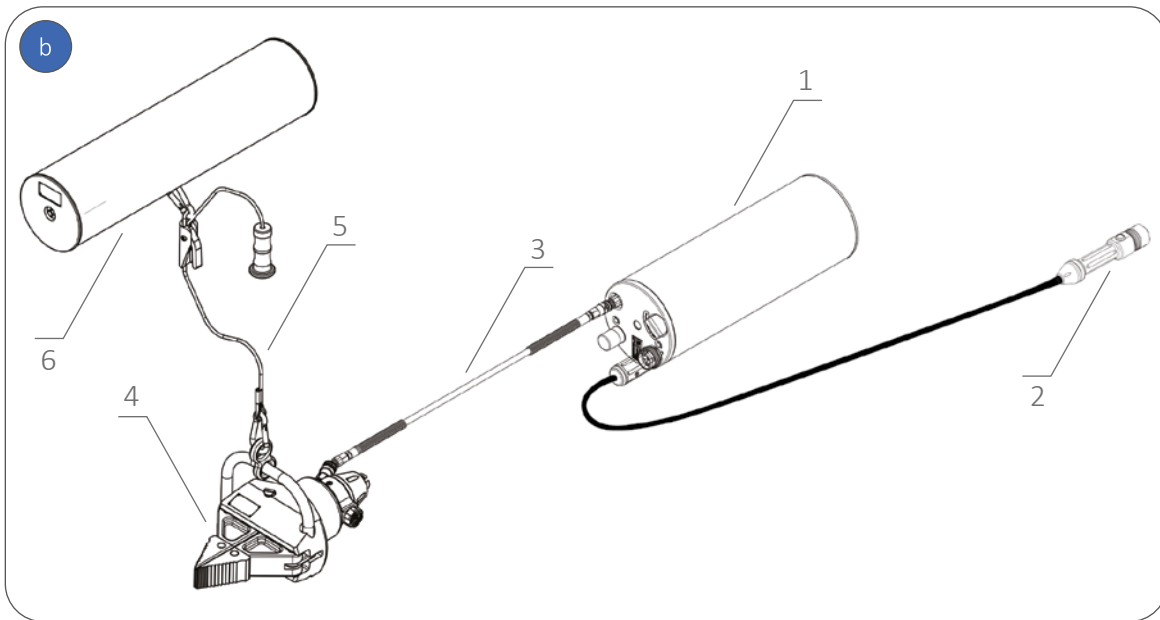
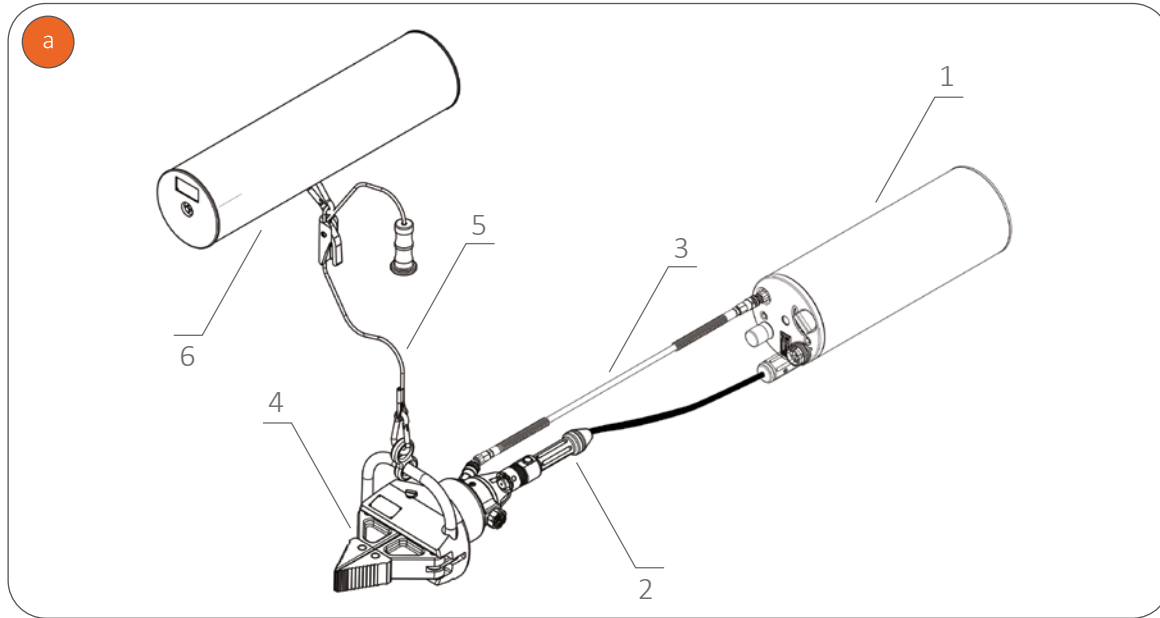

# M3864

land, watery & underwater spreading unit

- |     |   |  |
|-----|---|--|
| M38 | } | 1 Mpower - hydraulic power unit                                    |
|     |   | 2 Mconnect2 or Mconnect4 - service handles / cabled remote control |
|     |   | 3 Mflex2 or Mflex4 - hydraulic hoses                               |
| M64 | } | 4 ME4 - spreader   |
|     |   | 5 Mrope - length adjustable sling for spreader and buoy            |
|     |   | 6 Mstab-64 - spreader's neutral buoyancy buoy and safety sling     |

Hydraulic couplings and electrical connectors can be connected and disconnected underwater.

The Mstab can float at a horizontal or at a vertical position.

The Mrope is a length adjustable sling placed between the spreader and the Mstab.

The Mstab and the weight bags work together to give the spreader its neutral buoyancy.

The Mpower is used weight bags too to get neutral buoyancy.

The usual way to use the Mconnect2 & Mconnect4 is attached to the spreader. If, for safety reasons, it is preferable to operate from a distance, you can release the remote control from the tool.

The spreader can be used either way:



When spreading or lifting, the operator, holding the handle, will start the spreader by pushing on the button on the service handle (2).



For safety reasons, the operator can remotely control the spreading or lifting process by pushing on the button on the release service handle (2).





# M3864

land, watery & underwater spreading unit





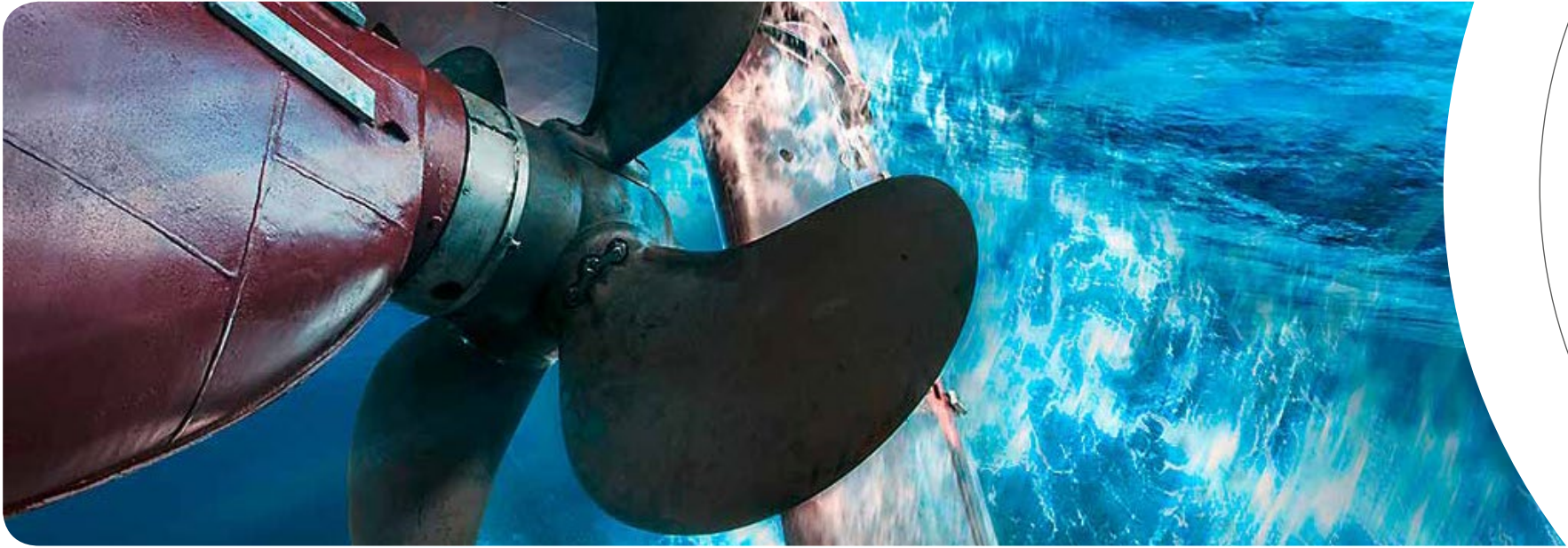

# M3865

land, watery and underwater sabotage & heavy-duty work unit

The M3863/64/65 unit was developed for atypical breaching situations faced by the operation's teams of the Police and Army.

Through many technical meetings with concerned parties, we defined their needs exact specifications. It seemed that during specific missions, either on land or underwater, they lacked the proper tools to cut, prise open, raise or push; tools that could be silent and self-sufficient, and that would not produce any air bubbles when in use.

**Designed for heavy-duty work & sabotage, the M3865 comes with a telescopic jack, its extension, a buoy, a hydraulic hose combined with an electric service handle and a hydraulic power unit.**

Be it on an automotive vehicle, a vessel, an aircraft, etc. the MVT5 and its RMVT5 extension will be a great solution for any breaching operations on land or underwater.

With the Mstab buoy the MVT5 keeps its mobility and has a neutral buoyancy leaving the diver free of any weight. When used from a distance, the spreader maintains its neutral buoyancy even after cutting or spreading giving the operator and the equipment full safety. On the Mstab can be found a pocket designed for the RMVT5 storage.

The Mpower hydraulic power unit with the T360 technology feeds the MVT5, works in any positions and has neutral buoyancy. The integrated and re-loadable battery provides 45 minutes of working autonomy.

The combined 2 m - 6 ft hydraulic hose and electric service handle connects the hydraulic power unit to the telescopic jack is used to power the Mpower from the tool. The standard distance between the operator and the tool is 4 m- 13 ft. If a longer distance is required, we can provide an additional 4 m- 13 ft dual hydraulic hose/ electric service handle, providing an 8 m- 26 ft safe lifting/spreading distance from the working tool.

Note that if you also own a cutter or a spreader or both you can use either tool with the Mpower and use them one after the other.

To do so, disconnect the service handle from the tool you are using and connect it to the required tool, you can proceed both on land and underwater.





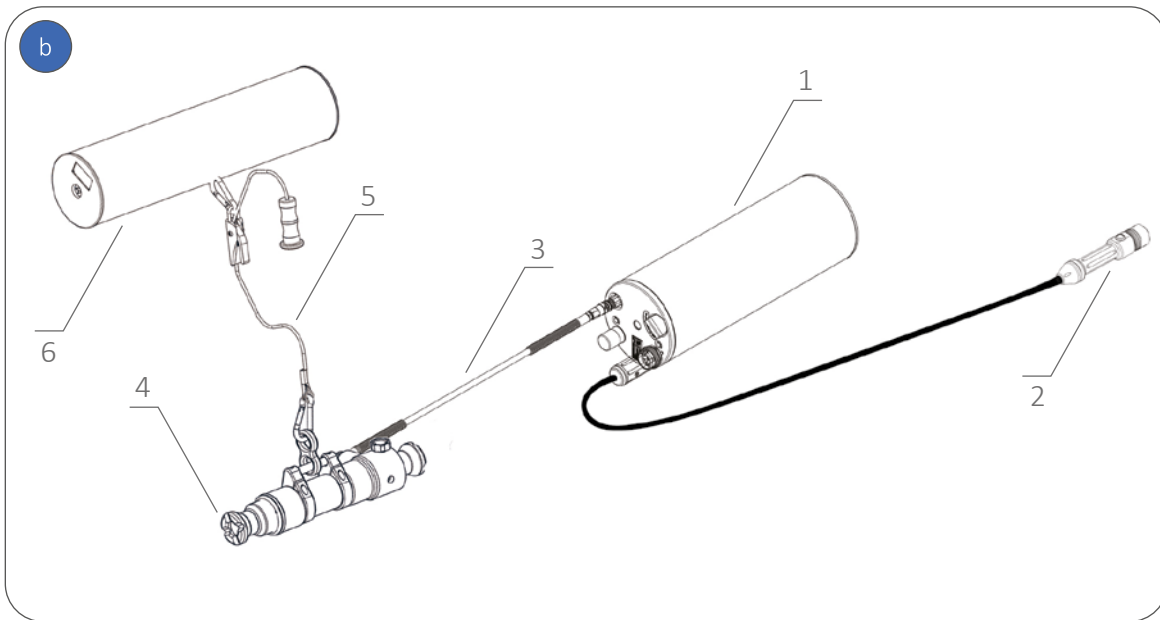
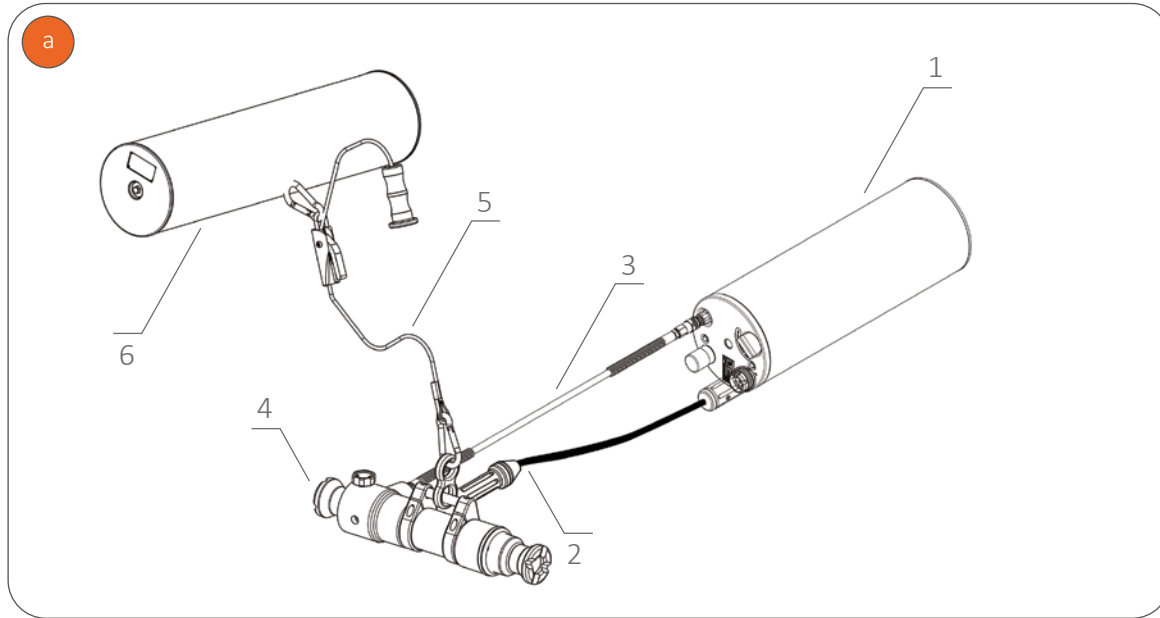

# M3865

land, watery and underwater sabotage & heavy-duty work unit

- |     |   |  |
|-----|---|--|
| M38 | } | 1 Mpower - power unit  |
|     |   | 2 Mconnect2 or Mconnect4 - service handles / cabled remote control |
|     |   | 3 Mflex2 or Mflex4 - hydraulic hoses                               |
| M65 | } | 4 MVT5 - telescopic jack and RMVT5 extension                       |
|     |   | 5 Mrope - length adjustable sling                                  |
|     |   | 6 Mstab-65 - hydraulic jack's buoy                                 |

Hydraulic couplings and electrical connectors can be connected and disconnected underwater.

The Mstab can float at the horizontal or at the vertical position.

The Mrope is a length adjustable sling placed between the jack and the Mstab.

The Mstab and the weight bags work together to give the cutter/spreader/jack its neutral buoyancy.

The Mpower is used with weight bags too to get neutral buoyancy.

The usual way to use the Mconnect2 & Mconnect4 is attached to the cutter/spreader/jack. If, for safety reasons, it is preferable to operate from a distance, you can release the remote control from the tool.

The telescopic jack can be used either way :

- a** When spreading or lifting, the operator, holding the handle, will start the tool by pushing on the button on the service handle(2).
- b** For safety reasons, the operator can remotely control the spreading/lifting, process by pushing on the button on the release service handle(2).

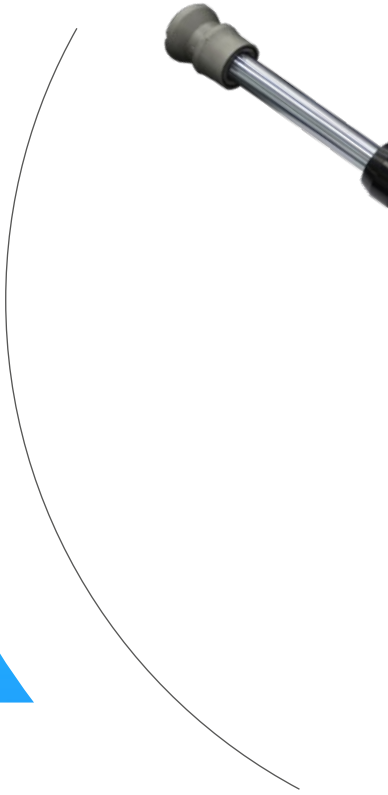

# M3865

land, watery and underwater sabotage & heavy-duty work unit







# M3863/64/65

land, watery & underwater cutting, spreading, lifting & pushing units

The M3863/64/65 unit was developed for atypical breaching situations faced by the operation's teams of the Police and Army.

Through many technical meetings with concerned parties, we defined their need exact specifications. It seemed that during specific missions, either on land or underwater, they lacked the proper tools to cut, prise open, raise or push; tools that could be silent and self-sufficient, and that would not produce any air bubbles when in use.

**Designed to cut, spread, lift and push, the M3863/64/65 comes with a cutter, a spreader and a jack, their own buoyancy float, a hydraulic hose combined with an electric service handle and a hydraulic power unit.**

Within the cutters' range four different models are available from the Mseries cutters : short curved blades MBP40 & long curved blades MBPL40, short straight blades MLD40 & long straight blades MLDL40 and the U shape blades MU400.\*

All cutters will cut through 22 millimeters' diameter steel bars\* (1 inch), chains, all kind of metal profiles, but also, electrical cables, composite materials, etc.

The MBP40, MBPL40, MLD40, MLDL40, MLD40 or MU400 cutter, the ME4 spreader and the MVT5 telescopic jack will be a great solution for any breaching operations on land or underwater.

Each tool comes with its own buoy keeping its mobility at all time with neutral buoyancy leaving the diver free of any weight. When used from a distance the cutter, spreader and jack will keep their neutral buoyancy after cutting, spreading, or lifting ensuring the diver his safety as well as the equipment one.

With the patented T360 technology the Mpower hydraulic unit works in all position and also benefits from a neutral buoyancy.

The integrated battery offers a 45 mn of tool action. A hydraulic hose and a 2 m long service handle connect the power unit to the tool giving the diver the possibility to action the power unit from the tool.

For security reasons it is possible to disconnect the service handle from the tool and use it as a remote control to cut, spread or lift at a safe distance.

The standard version gives a 4 m distance between the tool and the diver if a longer distance is needed, we can supply as an option a 4 m long service handle making it possible to work away from the tool with an 8 m safety distance.

The hydraulic unit supplies either tools. Disconnect the hydraulic hose and the service handle from the tool in use and connect it to the one you want. This can be done on land and underwater.



\* All cutting test were done using standard steel, Ø 22 mm- 0,8 inch bar, NF S235/EN10027

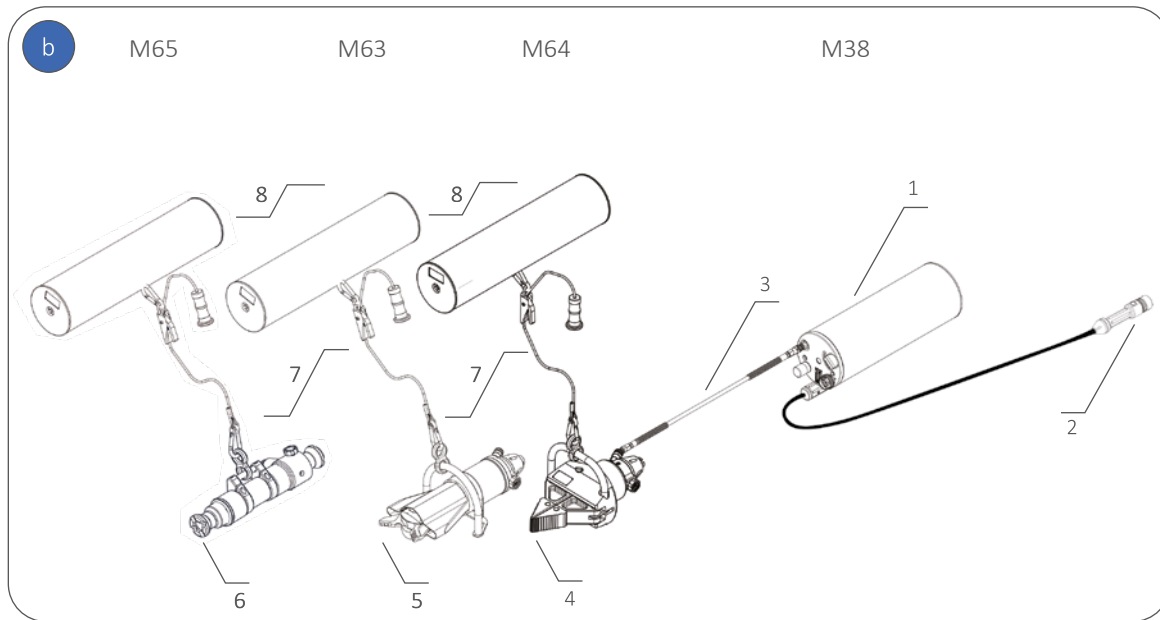
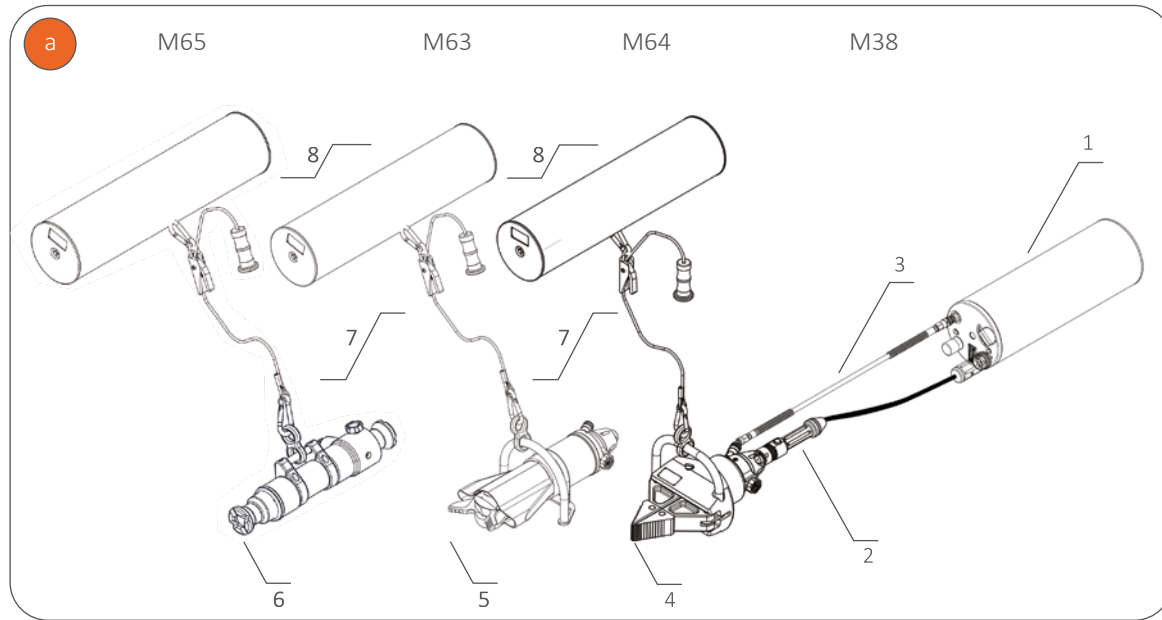

# M3863/64/65

land, watery and underwater extrication & heavy-duty work unit

M38	1	Mpower - hydraulic power unit
	2	Mconnect2 or Mconnect4 - service handles / cabled remote control
	3	Mflex2 or Mflex4 - hydraulic hoses
M63/64/65	4	ME4- spreader
	5	Mseries or MU400 - cutters
	6	MVT5 - telescopic jack and RMVT5 extension
	7	Mrope - length adjustable slings for cutter / spreader / jack and buoys
	8	Mstab-63 - Mstab-64 - Mstab-65 - cutter / spreader / jack's neutral buoyancy buoys and safety slings

Hydraulic couplings and electrical connectors can be connected and disconnected underwater.

The Mstab can float at the horizontal or at the vertical position.

The Mrope is a length adjustable sling placed between the cutter/spreader/jack and the Mstab.

The Mstab and the weight bags work together to give the cutter/spreader/jack its neutral buoyancy.

The Mpower is used with weight bags too to get neutral buoyancy

The usual way to use the Mconnect2 & Mconnect4 is attached to the cutter/spreader/jack. If, for safety reasons, it is preferable to operate from a distance, you can release the remote control from the tool.

The cutter/spreader/jack can be used either way:

- a When cutting, spreading, lifting or pushing, the operator, holding the handle, will start the tool by pushing on the button on the service handle(2).
- b For safety reasons, the operator can remotely control the cutting/spreading/lifting/pushing, process by pushing on the button on the release service handle(2).







# M3863/64/65

land, watery and underwater extrication & heavy-duty work unit



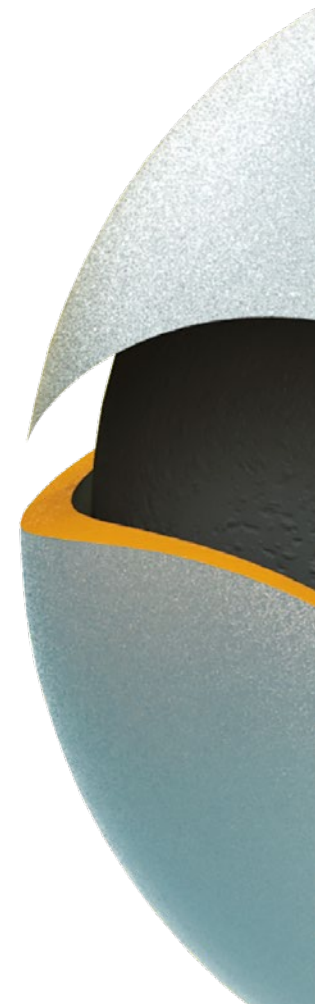

# OXsea

land, watery & underwater thermic cutting unit

The OXsea land, watery and underwater thermic cutting unit offers the most versatile possibilities for cutting and boring.

The rod ignites when sparks are created from the friction between the rod and the stainless-steel plate which is fed from a 12V reloadable battery.

The pressurized oxygen flow going through the rod generate the fusion necessary to cut the material.

The battery is used for ignition but not during the cutting process.

The oxygen feed brings temperature up to 5500C° (10000F°) which render the cutting of all kind of materials, such as stainless steel, aluminium, concrete, etc., possible. Rusting or seaweed will never hinder the cutting process.

For the users' safety and comfort we've developed and patented a 2 in 1 diving mask (diving/cutting). Its retractable UV shield protects the eyes while cutting and can be folded back to dive.

The OXsea unit is delivered with: a 25 cutting rods' box, a retractable UV shield diving mask, a maintenance bag with spare battery, a slip joint pliers, an extractor, a battery indicator, an oxygen grease tube and a spring collet for spare electrodes.

The Oxsea and its accessories are delivered in a Pelicase.

We chose Pelicases as a guarantee for quality and long life to deliver different kind of equipment for almost 20 years. These are the strongest and the most reliable cases on the market. All our cases meet military and air transport standards. Pelicases are waterproof.





# OXsea

land, watery & underwater thermic cutting unit



thermic cutting unit	ref. OXsea
power unit	yes
power unit battery charger	yes
battery indicator	yes
power unit dimensions	250 x 350 mm - 9.84 x 13.78 inch
power unit weight	12 kg - 26.5 lbs
power unit colour	dark grey/black nylon (option olive green)
6 litres oxygen bottle	yes
oxygen bottle dimensions	134 x 628 mm - 5.28 x 24.72 inch
oxygen bottle weight empty	7.4 kg - 15.43 lbs
oxygen bottle cover colour / available colours	dark grey/black nylon (option green olive or camouflage)
regulator & manometer	yes
safety check-valve	yes
thermic torch	yes
oxygen hose's length	1.5 m - 5 ft
ignition plate with electric cable	1.2 m - 4 ft
25 cutting rods' box	yes
cutting rods type	Ø 9.5 mm - 3/8" - length 480 mm - 19"
retractable UV shield diving mask	yes
level 1 maintenance tool bag	yes
maximum depth	80 m - 262 ft
underwater connection / disconnection	yes
land / underwater use	yes
carrying handles	yes
neutral buoyancy	yes
weight bags	yes
OXsea full weight	29.9 kg - 66 lbs
fully equipped Pelicase weight	46 kg - 101 lbs
delivered with OXsea	yes
underwater air bubbles production	yes

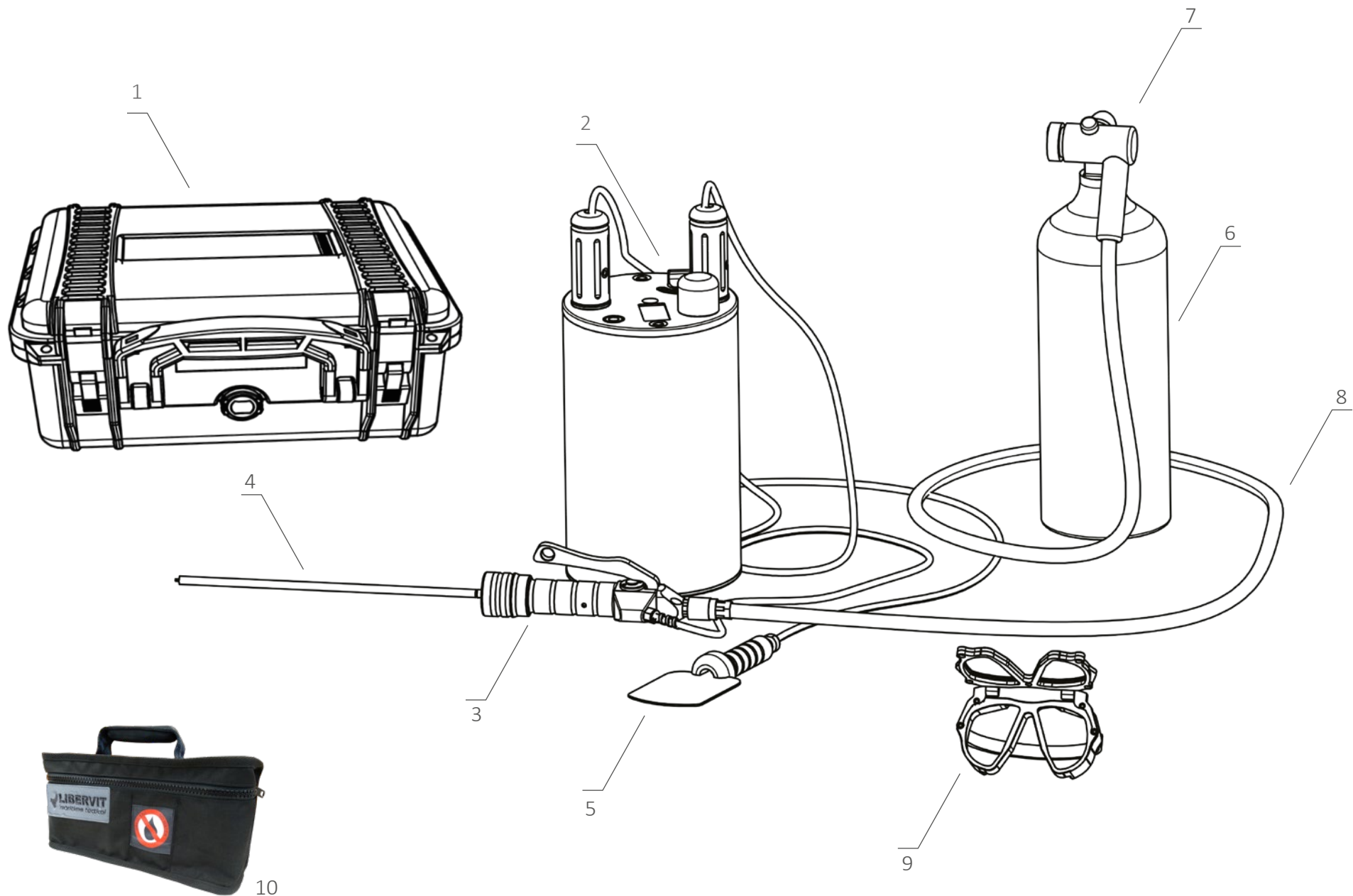

- 1 Pelicase transport case includes :
- 2 OXsea - power unit
- 3 Thermic torch
- 4 Cutting rod - Ø 9.5 mm - lenght 480 mm (25 rods)
- 5 Ignition plate & 1.2 m - 4 ft electric cable
- 6 Oxygen bottle
- 7 Regulator - manometer for oxygen level - safety check-valve
- 8 1.5 m - 5 ft long fast coupling oxygen hose
- 9 Retractable UV shield diving mask
- 10 Maintenance bag

The OXsea unit is delivered with: a 25 cutting rods' box, a retractable UV shield diving mask, a maintenance bag with spare battery, a slip joint pliers, an extractor, a battery indicator, an oxygen grease tube and a spring collet for spare electrodes.

The Oxsea and its accessories are delivered in a Pelicase.

We chose Pelicases as a guarantee for quality and long life, to deliver different kind of equipment for almost 20 years. These are the strongest and the most reliable cases on the market. All our cases meet military and air transport standards. Pelicases are waterproof.





# OXsea

land, watery & underwater thermic cutting unit







The LIBERVIT training cage is disposable.

Underwater hydraulic cutters, spreaders and thermic torch will be easily tried out on highly resistant metals.

Whether used in a pool or at sea, on a surface or suspended, the Tcage with its diverse chains and bars, is the cheapest training option available for anyone wishing to master their cutting/spreading techniques.





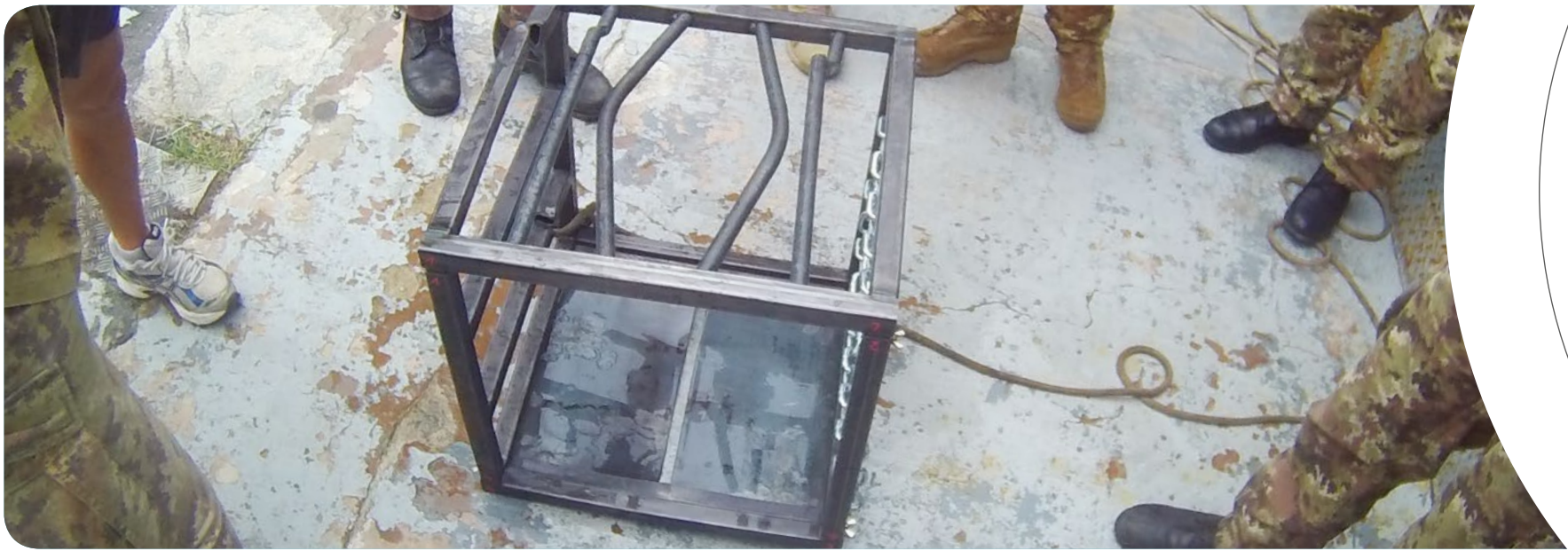

# Tcage

training cage



reference	Tcage
dimensions (non-assembled)	500 x 500 x 120 mm- 20 x 20 x 5 inch
dimensions (assembled)	500 x 500 x 500 mm- 20 x 20 x 20 inch
weight	21 kg- 46 lbs
disposable	yes
components	stainless steel
solid steel bars	qty 4, Ø 20 mm - Ø 0.8 inch
solid square bars	qty 3, 20 x 20 mm - Ø 0.8 inch
hollow square bars	qty 3, 30 x 30 mm - Ø 1.2 inch
chains	qty 3, Ø 10 mm - Ø 0.4 inch
delivered non-assembled	yes
assembling time	5 minutes
tools to assemble	not needed
colour	steel













# OL-GSG/FLEXDURA

dry diving suit



dry diving suit  
 3 BUTYL mixed fabric layers  
 1st layer fabric  
 2nd layer fabric  
 3rd layer fabric  
 colours  
 weight  
 waterproof  
 tear resistance  
 abrasion resistance  
 chest  
 knee-elbow- back  
 hood  
 socks  
 braces  
 valve  
 extra valve port  
 exhaust valve  
 crotch strap  
 neck and cuffs  
 cargo pocket  
 velcro  
 patches  
 MOLLE plate  
  
 inflation hose  
 transport bag  
 maintenance kit

ref. OL-GSG/FLEXDURA  
 440 g/m<sup>2</sup>  
 100% polyester- 150 gr/m<sup>2</sup>  
 Fabric coated with BUTYL- 80 gr/m<sup>2</sup>  
 100% Polyester- 210 gr/m<sup>2</sup>  
 SAR orange / black  
 3.5 kg (size: L)  
 up to 30 m  
 75 N x 55 N  
 40.000 Martindale  
 protective front PU zipper (back one on request)  
 padding (black)  
 FFM adapted  
 sole reinforced neoprene socks (to wear with amphibian boots)  
 integrated  
 inflating CEJN on chest  
 on left thigh with valve tools  
 left forearm- high flow  
 elastic  
 superstretch neoprene closing system (optional: latex or HD silicone)  
 on thigh with velcro and fixation strap  
 on sleeves (100 x 100mm) on hood (50 x 50mm)  
 SOLAS reflective  
 on left thigh to connect an emergency inflation system  
 or BCD emergency gas inflation system(EIS./BSGIS)  
 CEJN 80cm  
 yes  
 yes

Made in Austria, the OL-GSG/FLEXDURA was especially designed for special forces. The fabrics conception gives a new dimension to the dry suit world. Light, elastic, quick drying, durability against abrasion and highly visible.



# OL-TACTICAL LIGHT & OL-THERMOLOFT

dry diving suit & thermal undersuit



dry diving suit  
fabric  
colours  
drain & inflation valve  
exhaust valve  
padding  
closing system  
sleeves tightness  
hood  
feet  
chest  
available sizes  
weight  
grease tube (zipper)  
transport bag

ref. OL-TACTICAL LIGHT  
nylon coated PU  
SAR orange / black  
CEJN  
low flow  
CORDURA fabric (chest, knees, elbows & buttocks)  
PU zipper  
latex around neckline- cuffs  
extra  
integrated neoprene socks  
ajustable  
all sizes  
2.2 kg (size: L)  
yes  
yes

The OL-TACTICAL LIGHT is designed as a multi-purpose dry suit perfect to progress in any environment even hot and humid thanks to its light & breathable material. Use it to dive in cold water wearing a thermal undersuit.

thermal undersuit  
fabric  
closing system  
pockets  
washable  
available sizes

ref. OL-THERMOLOFT  
polar fleece  
double way zipper  
qty 3  
40°C  
all sizes

The perfect dry suit complement. Light , hydrophobic, breathable, good thermal regulation, it guarantees warmth and confort. Front zipper with 2 sliders and a close fitting cut for confort and freedom of mouvement.



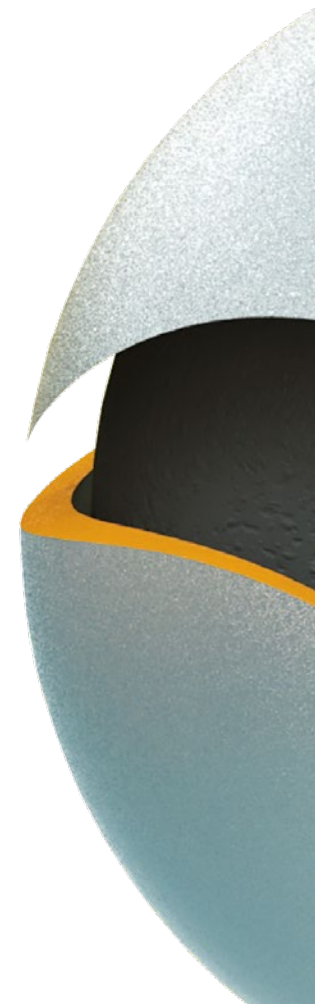

# Maintenance

maintenance equipment

Maintenance is a key factor in any technical equipment lifespan.

With underwater equipment it is essential to respect a proper maintenance procedure to both keep the equipment at its best performances and lower the risk when in use.

Within the following pages, you will find all the technical information needed to understand the different tools we recommend using to optimize the equipment maintenance.





# Air compressor & air gun

maintenance equipment



air compressor	ref. COMP/8B (BLACK+DECKER ref. BDCINF18)
inflator nozzle	LIBERVIT tools adapted nozzle
high pressure hose	60 cm- 23 inch
high volume hose	40 cm- 16 inch
pressure	160 PSI/ 11 BAR
feed source 1	220-230 VOLTS alternating current
feed source 2	12 VOLTS direct current / 12 VOLTS auxiliary power outlet
feed source 3	18 VOLTS Lithium battery
battery	Lithium, qty 1, ref. BL1518 (BLACK+DECKER)
automatic stop	yes
dimensions	260 x 200 x 180 mm- 10 x 8 x 7 inch
weight	2 kg- 4.4 lbs
B&D accessories	not included
transport bag	yes, ref. ST/COMP/8B
air gun	ref. MAN10
maximum pressure	12 bar
gun with LIBERVIT adapted nozzle	yes
delivered with manometer	yes
delivered in a solid plastic transport case	yes
case dimensions	292 x 341 x 100 mm - 11.5 x 14.5 x 4 inch
total weight	1.2 kg - 2.5 lbs





# ODMM

M3863 - M3864 - M3863/64 - M3863/64/65 maintenance case



The ODMM case provides all the tools your qualified staff needs to carry out all the Level 1 maintenance as well as some parts replacement on the cutter, the spreader and the hydraulic unit.

The ODMM\* case comprises:

- 1 torque wrench
- 1 22 combination spanner
- 1 21 combination spanner
- 2 19 combination spanner
- 1 slip joint plier
- 1 rubber hammer
- 1 set of Allen Key
- 1 Ø 3-10 circlip plier
- 1 Ø 10-20 circlip plier
- 1 keystone tip screwdriver
- 1 Phillips tip screwdriver
- 1 lubrication spray can
- 1 MOLYKOTE 55 grease tube
- 1 manometer
- 1 air gun
- 1 silica gel cartridge
- 1 extractor
- 1Mstab's extractor link
- 1 cloth

maintenance case reference  
 delivered in PELICASE transport case  
 case dimensions  
 total weight (with maintenance tools)

ODMM  
 yes, ref. ODMM  
 113 × 41 × 16 cm - 44 × 16 × 6 inch  
 14.5 kg - 2 st

\*On option when buying an M3863 - M3864 - M3863/64 - M3863/64/65 unit.



# OXtoolbag

maintenance bag for OXsea



Maintenance is key to maintain technical equipment on the long term.

For all underwater equipment, maintenance must be respected to ensure both the highest performance and lower the risk when in use.

The OXtoolbag is a complete Tool-bag containing all the instruments needed for qualified staff to perform the underwater thermic unit OXsea maintenance.

The LIBERVIT OXtoolbag\* includes:

- 1 set of Allen keys
- 1 Keystone tip screwdriver
- 1 Philips tip screwdriver
- 1 rubber hammer
- 1 slip joint pliers
- 1 stainless steel brush
- 1 oxygen grease tube
- 1 MPE key cover extractor

maintenance bag  
bag dimensions  
total case weight tools included

ref. OXtoolbag  
54.5 x 16 x 15 cm - 21 x 6 x 6 inch  
3 kg - 6 lbs

\*On option when buying an OXsea.





# GC/120

floor blanket

Made of PVC, the GC/120 floor blanket is ideal to provide a clean and safe environment to put down your tools and equipment when in operations in dirty or risky area.

reference	GC/120
component	grey PVC
transport handle	yes
washable	yes
dimensions opened	1200 x 1500 mm - 4 x 5 ft
weight	1.6 kg - 3.5 lbs





# DS80

depth simulator

Any underwater equipment need to undergo thorough testing to check its tightness before shipping.

During their lifetime, equipment and tools will need to be checked for tightness on a regular basis to maintain their highest performances and be safe to use.

LIBERVIT has designed a portable tightness testing tank to ease the testing process as this is not always doable or accessible.

Our testing tank reproduces all the mechanical stresses withstood during a dive. This means that you will no longer need to use the services of a private contractor.

The LIBERVIT depth simulator is easy to use: simply plunge the equipment to test in the fresh water filled tank and close the testing bench cover. The equipment will be tested at the same pressure than the one found by 80m (262ft) depth.







# DS80

depth simulator

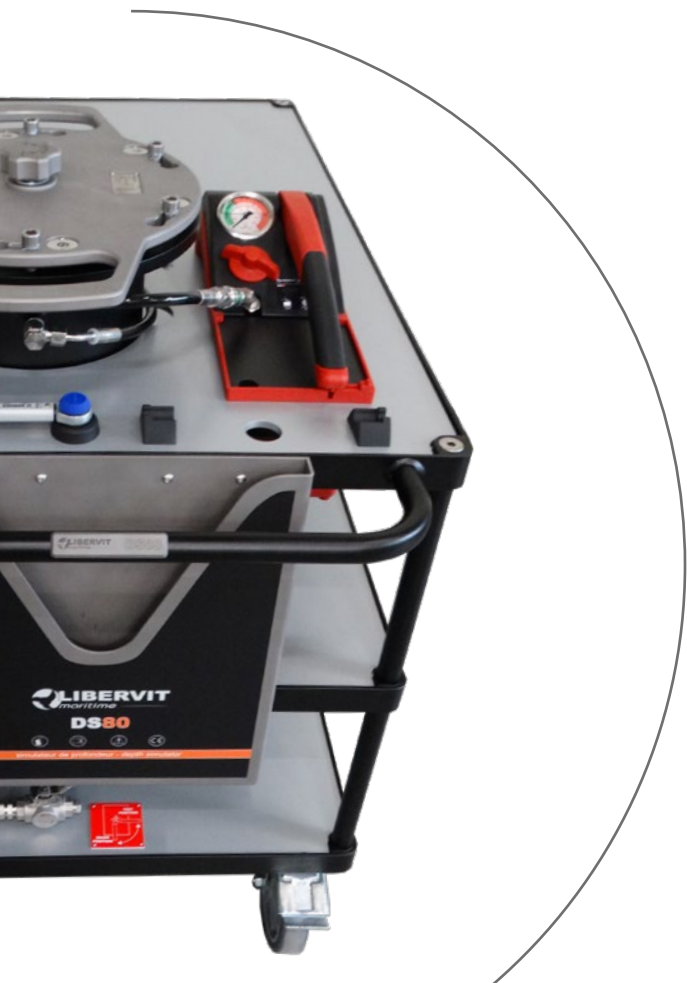

depth simulator  
dimensions including chassis  
weight empty  
depth simulated  
fill with  
water manual pump  
pressure indicator  
chassis on wheel  
2 rotating wheels with brakes  
tank for power unit  
tank for buoy  
drain tap  
handling spanner  
torque wrench

ref. DS80  
1200 x 700 x 1000 mm- 4 x 2 x 3 ft  
126 kg- 19.8 ft  
80 m- 262 ft  
fresh water  
yes  
yes  
yes  
yes  
yes  
yes  
yes  
qty 1  
qty 1



# LIBERVIT TRAINING COURSES

For any extrication operation on land or underwater the success or failure can be accounted for by the tool performance or the user's skills.

We offer training to specialized intervention groups to learn the tools maintenance and commissioning in any humid or watery area as well as underwater.

We will do our best to answer your training requests and to match our calendar with your schedule.

LIBERVIT- Espace Polygone - 218 rue Ettore Bugatti - 66000 Perpignan - FRANCE

Phone : + 33 (0)4 68 50 05 25 - Fax : + 33 (0)4 68 66 98 97 - [courrier@libervit.com](mailto:courrier@libervit.com) - [www.libervit.com](http://www.libervit.com)





This catalogue's information are not contractually binding. With the aim of improving its products, LIBERVIT reserves the right to modify their specifications without prior notice.

COPYRIGHT - All right reserved. Non-contractual photos.  
Photos' credit : SDIS66 | © Yvan Chocloff | SYANS | LIBERVIT communication

Design: LIBERVIT communication | [communication@libervit.com](mailto:communication@libervit.com)

LIBERVIT - Espace Polygone - 218 rue Ettore Bugatti - 66000 Perpignan - FRANCE  
Phone : + 33 (0) 4 68 50 05 25 - Email : [courrier@libervit.com](mailto:courrier@libervit.com)

# LIBERVIT

our other ranges



extrication tools



hydraulic door opener / force entry



entry tools



land & underwater tactical equipment



[libervitmaritime.com](http://libervitmaritime.com)